

GUIDELINES FOR ROAD DESIGN, CONSTRUCTION, MAINTENANCE AND SUPERVISION

Volume I: DESIGNING

Section 2: DESIGNING BRIDGES

DESIGN GUIDELINES (DG 1.2.7)

Part 7: EXPANSION JOINTS ON BRIDGES

INTRODUCTION

Expansion joints are movable joints between the bridge superstructure and the abutment or between two parts of the bridge superstructure.

Bridge designers should tend to such bridges that do not require any expansion joints. When expansion joints are inevitable, their number shall be small as possible.

Expansion joints, particularly those for large movements, are designed, selected and installed extremely professionally. Recent findings based on investigation and monitoring of built-in expansion joints are taken into consideration. Up-to-date materials of highest quality offered by professional, proven and reliable manufacturers are employed.

Only such expansion joints shall be installed that ensure a faultless waterproofing and a perfect and controlled drainage. In addition, they shall fulfil the following requirements:

- to be able to accommodate all expected movements,
- to be reliable and resistant when taking loads,
- to resist corrosion and abrasion actions,
- to be noiseless when passed by vehicles,
- to have a long period of life,
- to ensure simple control, maintenance, repair, and replacement.

CONTENTS

1. SUBJECT OF DESIGN GUIDELINES	5
2. REFERENCE REGULATIONS	5
3. EXPLANATION OF TERMS	5
4. BASIC REQUIREMENTS	6
4.1. Bridge conception.....	6
4.2. Selection of adequate expansion joint	6
5. TYPES AND FIELDS OF APPLICATION	6
5.1. Waterproof expansion joints.....	6
5.2. Expansion joints for minimum movements	7
5.3. Expansion joints for small movements.....	8
5.4. Expansion joints for medium movements	9
5.5. Expansion joints for large movements	9
5.6. Expansion joints for extremely large movements	10
6. APPOINTMENT OF EXPANSION JOINTS AND ACCOMPANYING TECHNICAL DOCUMENTS	10
6.1. Design calculation in general	10
6.2. Calculation of movements in expansion joint.....	11
6.3. Drawings	11
7. Requirements for bridge structure in expansion joint area	13
7.1. General.....	13
7.2. Bridge superstructure.....	14
7.3. Bridge substructure	14
7.4. Waterproofing, asphalt, kerbs and walkways with edge beams	14
7.5. Drainage.....	16
7.6. Checking of procedures prior to placing an order for expansion joint.....	16
8. TAKING OVER, INSTALLATION, MAINTENANCE, AND REPLACEMENT OF EXPANSION JOINT	18
8.1. Taking over of expansion joint from manufacturer.....	18
8.2. Installation of expansion joint	18
8.2.1. Installation of bituminous expansion joints and elastomer fillers	18
8.2.2. Installation of rubber expansion joint	18
8.2.3. Execution of waterproofing at expansion joint	20
8.2.4. Application of wearing course at expansion joint.....	20
8.2.5. Inspection and maintenance of expansion joints	20
8.2.6. Replacement of expansion joints	20
8.2.7. Attestation of expansion joints	20

1. SUBJECT OF DESIGN GUIDELINES

The intention of the present DG 1.2.7 is to define criteria for determination of the expansion joint type and to give technical conditions for its proper design, installation and use.

Within the present framework, the guidelines specify bases for calculation of the expansion joint moving capacity. In the subsequent chapters, instructions for designing of expansion joints are given. Moreover, requirements to be fulfilled by the bridge structural elements to enable a reliable installation and subsequent function of expansion joints are indicated as well.

Essential constructive details of expansion joints in the carriageway area, pedestrian walkway and edge beam are presented.

In the second part of this design standard, installation, inspection, maintenance, and replacement procedures for expansion joints are determined.

2. REFERENCE REGULATIONS

The present design guideline includes foreign codes and other technical regulations stated in corresponding passages of the subsequent text. The latest edition is always valid.

- Structural bearings and expansion joints for bridges, Structural Engineering Documents IABSE, Zürich, 2002;
- DIN 1072;
- Austrian guidelines RVS 15.45: Bridge Equipment – Expansion Joints, 1985 (Brückenausrüstung Übergangskonstruktionen);
- TL/TP-Fü, Germany.

3. EXPLANATION OF TERMS

Asphalt expansion joint is a term for the wide assortment of expansion joints where the extensible part of an expansion joint is made of a mixture for which the term “asphalt” has become familiar.

Bituminous expansion joint is a narrower term for an asphalt expansion joint whose extensible part is made of a mixture of polymerized and/or elastomer enriched bitumen, and of stone-filler.

Bituminous sealing compound consists of polymerized bitumen. It is used for sealing of joints where asphalt layers are connected to the expansion joint elements.

Concrete structure is a wider expression for a part of the bridge structure, constructed of cement concrete onto or into which expansion joint elements are fastened or anchored.

Seepage water pipe is a specially shaped small pipe serving to drain the water arising from the concaves at expansion joint and seeping through the asphalt layers.

Expansion opening is the spacing between structural elements that is bridged by the expansion joint.

Expansion joint is an element bridging the movable joint between the superstructure and the abutment or between two parts of the superstructure.

Simple expansion joint is an element installed into the joint between the bridge carriageway and the connecting road carriageway. In general, this applies to minor bridges and to roads of lower ranking.

Disconnecting of structure is a wider term for structural discontinuities enabling mutually independent moving of separated structural parts.

Elastomer is a wider term for the synthetic rubber possessing required physical and chemical properties. In bridge construction, chloroprene rubber is mainly used.

Comb is a constituent part of an expansion joint, shaped as a comb or saw where two elements extending one into another ensure continuity of the expansion joint surface.

Walkway is a part of the bridge carriageway intended for pedestrians and cyclists. It is usually raised above the carriageway.

Steel profile in expansion joints is a specially profiled steel girder on which a rubber seal is pressed or screwed.

Steel anchor is a round steel loop, a specially formed element made of steel plate, or a cylindrically shaped element, embedded in structural concrete, creating a rigid connection between the bridge structure and the expansion joint.

Dowel is a narrower term for steel anchor embedded in concrete or stuck into a preliminarily drilled hole.

Expansion joint opening is the width between stiff elements of an expansion joint. It depends on setting and functioning of the structure, and determines the expansion joint moving capacity.

Movement of expansion joint is a common term for all possible movement vectors in the expansion joint axis, including rotation.

Temperature expansion is an expression for shortening or lengthening of structural elements due to their temperature change.

4. BASIC REQUIREMENTS

The present design guideline deals with expansion joints on road bridges.

4.1. Bridge conception

When designing a bridge, designers shall tend towards such a conception where no expansion joint or a minimum number of expansion joints is required.

Designers shall take into consideration that installation of extremely oblique and/or curved expansion joints with branches, or expansion joints of greater longitudinal and transversal falls, and other expansion joints of irregular shape, requires special executions with unverified details. Such expansion joints are less reliable, more complicated for inspection and maintenance, and make construction more expensive. Therefore, expansion joints of such kind shall already be avoided in the early stage of bridge design.

Furthermore, the bridge designer is obliged to bear in mind that expansion joints must be perfectly designed in all the structural elements, i.e. in the carriageway as well as in the areas of kerbs, pedestrian walkways and cycle tracks, edge beams, bordures, concrete safety barriers etc. Therefore, those elements shall be designed with care as well.

When several bridges are constructed on one road section, expansion joints shall be made uniform if possible. In this way, control and maintenance are simplified and the costs reduced.

4.2. Selection of adequate expansion joint

All participants in the bridge construction are obliged to select expansion joints, in particular those for large movements, in an extremely professional manner. They shall take into consideration the newest knowledge based on researches and profound observations of expansion joints in service. The best solutions offered by reliable expansion joint manufacturers in a certain moment, shall be selected.

Up-to-date expansion joints shall be built to fulfil the following requirements:

- movements in both horizontal and vertical direction shall be ensured;
- they shall be perfectly waterproof and shall enable a perfectly waterproof drainage, respectively;
- load bearing capacity of their elements shall ensure the ultimate limit state, all the serviceability limit states, and the fatigue resistance for the entire service life;
- when passed by vehicles they shall not make any noise; they shall enable an adequate passing of all participants in traffic;
- they shall be resistant to corrosive actions including to abrasion due to sand on the carriageway, and to de-icing salts;
- their control, maintenance, repair, and replacement shall be made possible;
- their service life shall be long (depending on the expansion joint type; service life of asphalt expansion joints shall be at least as long as that of the asphalt carriageway);
- their price shall be reasonable and the quality guaranteed.

5. TYPES AND FIELDS OF APPLICATION

On bridges where the space below the expansion opening is not accessible, only waterproof expansion joints shall be installed.

5.1. Waterproof expansion joints

An expansion joint is waterproof when:

- a waterproof seal is installed that is water-tightly connected with the waterproofing layer on the bridge (figures 4, 8, and 9),
- a seal is water-tightly built-in into a steel bearing profile or a high-performance concrete pad to be water-tightly connected with the waterproofing layer on the bridge (figures 5, 6, 7), or

- a trapping gutter is installed in the expansion opening below the expansion joint; the following expansion joints belong to this group: expansion joints made of heavy rubber seals shown in figures 6, 8, and 9, and similar expansion joints where seals consist of several elements not interconnected water-tightly; comb

expansion joints (figure 10), and simple expansion joints with covering steel plate, which are installed in the walkway areas and less significant bridges.

In table 1, expansion joints are classified in different basic groups with regard to their moving capacity.

Table 1: Systematization of expansion joints

Point	Expansion joint type	Distance between adjacent expansion joints	Movement in expansion opening			Materials for expansion joint
			x-direction	y-direction	z-direction	
5.2	For minimum movements (carriageway end)	up to 20 (30) m	20 mm ¹⁾ (± 10 mm)	5 mm ¹⁾	5 mm ¹⁾	steel end profile and bituminous sealing compound
5.3	For small movements	up to 50 (70) m	50 mm (± 25 mm)	5 mm	1 mm ²⁾	polymerized bituminous sealing compound, elastomer filler, rubber, steel
5.4	For medium movement	up to 150 m	150 mm (± 50 mm)	5 mm ³⁾	1 mm ³⁾	rubber seal, bearing profiles, steel anchors, anchor bolts, etc.
5.5	For large movements ⁴⁾	up to 300 m	300 mm (± 150 mm)	5 mm ³⁾	1 mm ³⁾	rubber seal, steel anchors, steel bearing elements, steel combs and saws, heavy plates, elements of synthetic materials, etc.
5.6	For extremely large movements ⁴⁾	above 300 m	≥ 300 mm (± 150 mm)	5 mm ³⁾	1 mm ³⁾	

¹⁾ Indicated values of movements are approximate only; they are ensured by means of suitably shaped asphalt-concrete wedges.

²⁾ Limitation to 1 mm applies to bituminous expansion joints, e.g. Thorma Joint. Solutions with rubber seals are less sensitive to vertical movements.

³⁾ Indicated values are approximate only since the moving capacities in both y-direction and z-direction vary significantly for individual types of expansion joints with respect to their structural specificities.

⁴⁾ Expansion joints for large and extremely large movements are often water-permeable. In such cases a perfect drainage and an access below the expansion joint shall be ensured.

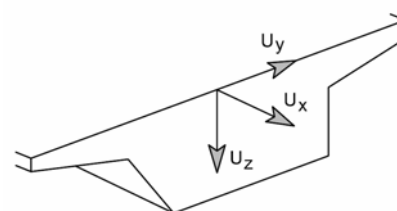

5.2. Expansion joints for minimum movements

In this case, an expansion joint is built-in into the joint between the bridge carriageway and the connecting road carriageway. This particularly applies to bridges where the bridge scheme (e.g. a frame structure) and the distance between adjacent joints or the road ranking do not require "true" expansion joints – only the carriageway end is carried out.

As a rule, a carriageway end is executed on motorway, main road and regional road bridges, on condition that their length does not exceed 20 m, and on bridges on roads of lower ranking, provided that they are not longer than 30 m. Expected deformations, bridge settlements, and connecting fill settlements shall be taken into consideration.

The sealing joint of the carriageway end is carried out during application of the wearing course or, afterwards, by means of a joint cutter. The latter procedure enables a better and continuous application of the wearing course.

The carriageway end shown in figure 1 is executed at the joint between the bridge asphalt carriageway and the road gravel carriageway.

For the execution of the carriageway end, details shown in DG 1.2.8 shall be taken into consideration as well.

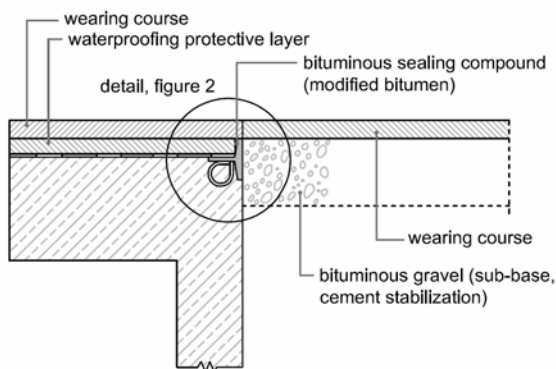

Figure 1: Principle of carriageway end

The joint is sealed with bituminous sealing compound made of modified bitumen (figure 1). For the execution of the end profile, a workshop drawing shall be worked out taking into consideration the geometry of the bridge carriageway (figures 2 and 3), as this is the case for the expansion joint bearing profiles.

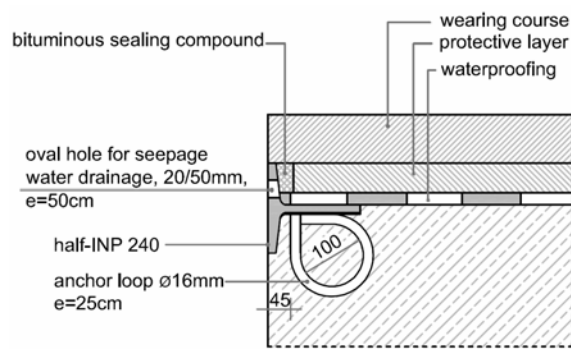

Figure 2: Detail of carriageway end

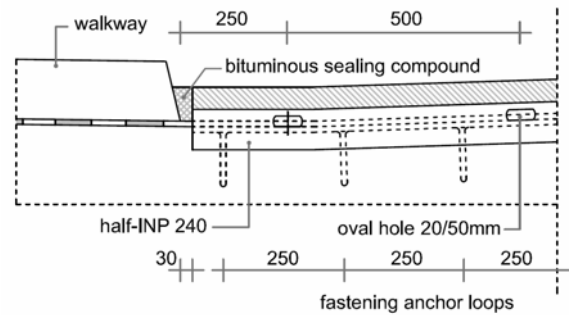

Figure 3: Carriageway end, end profile

5.3. Expansion joints for small movements

With respect to their execution, expansion joints for small movements are divided in two basic groups:

- asphalt expansion joints, and
- rubber expansion joints.

Asphalt expansion joints or **elasto-bituminous expansion joints** are made of polymerized bitumen having improved elastic properties. The material is poured into a groove in a previously executed asphalt carriageway thus becoming a constituent part of the carriageway.

Their fastening is ensured by sticking on the concrete base on the lower side, and by lateral sticking on or leaning against the layers of the asphalt-concrete carriageway (figure 4).

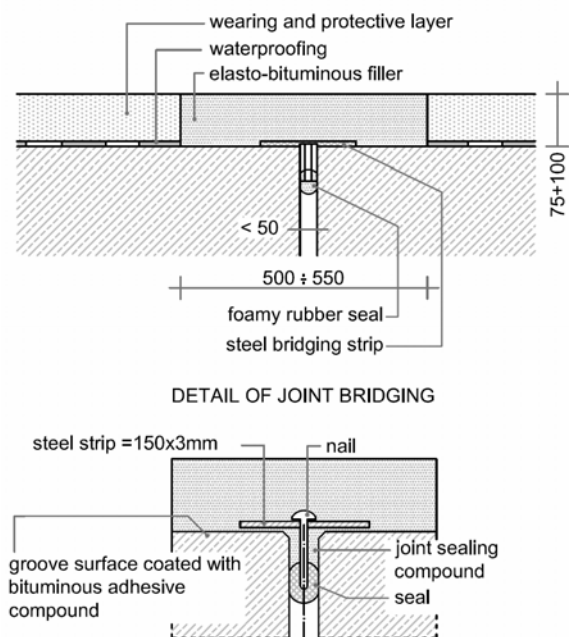

Figure 4: Principle of asphalt expansion joint

Rubber expansion joints consist of a steel bearing profile firmly anchored to the concrete structure on both sides of the joint, and of a rubber seal that is water-tightly fixed to the bearing profile (figure 5).

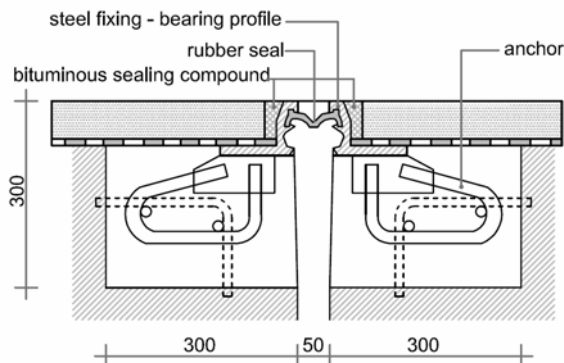

Figure 5: Principle of rubber expansion joint with anchors embedded in concrete

Expansion joints made of rubber seal screwed directly on the concrete structure on both sides of the joint (figure 6) belong to this group as well.

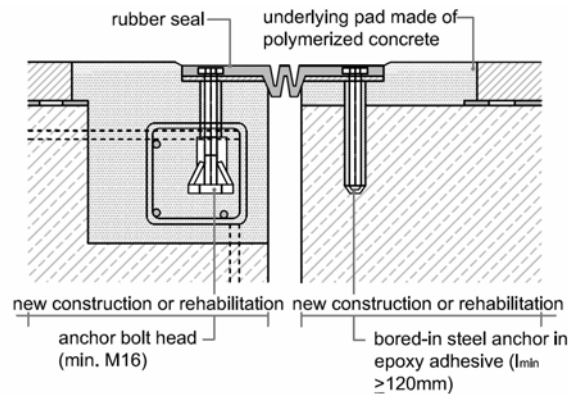

Figure 6: Principle of rubber expansion joint with screwed-on anchoring

Asphalt expansion joints are generally installed on road bridges where the distance between adjacent expansion joints does not exceed 50 m provided that the required moving capacity amounts to maximum 50 mm or to such a value that is guaranteed by the manufacturer.

Asphalt expansion joints shall not be foreseen when the resulting inclination of the bridge carriageway is greater than 5%, and when longitudinal movements greater than 10 mm or vertical movements greater than 1 mm appear in the joint axis.

When asphalt expansion joints cannot be built-in due to specific circumstances, rubber expansion joints for small movements shall be installed.

Asphalt expansion joints are preferential because they are simple, made of one material being similar to the material they are installed into, silent, and simple for maintenance and replacement.

5.4. Expansion joints for medium movements

Expansion joints of moving capacity up to 150 mm belong to this group. They are made of steel profiles with intermediate profiles supported in different ways (figure 7), and of rubber seal shown in figure 8, respectively.

5.5. Expansion joints for large movements

Expansion joints for large movements, with a movement capacity of up to 300 mm, are complex mechanical devices consisting of a great number of elements sensitive to wear and fatigue, and difficult to be maintained.

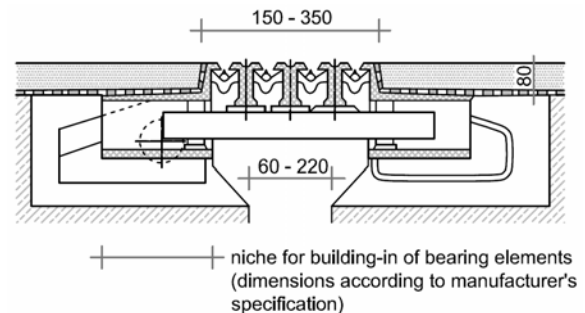

Figure 7: Expansion joints with intermediate profiles for medium and large movements

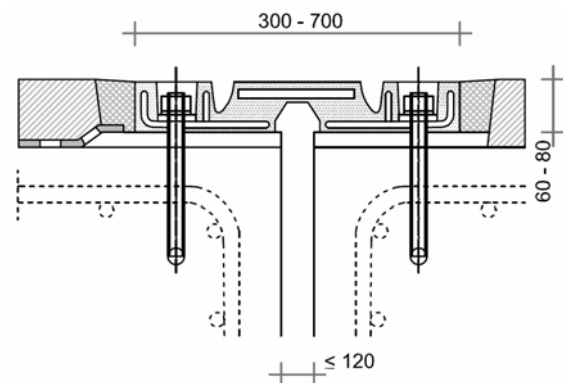

Figure 8: Expansion joint for medium movements with screwed-on anchoring

Expansion joints with heavy reinforced rubber seals are shown in figure 9. In case that the seals consist of several parts – blocks in the longitudinal direction (of common length $2,000 \div 3,000$ mm), which are not interconnected water-tightly, a seepage water trapping gutter shall be installed into the joint.

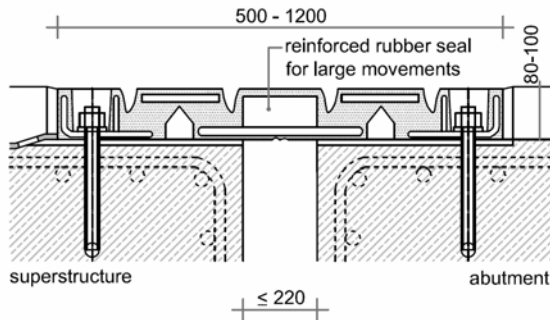

Figure 9: Principle of expansion joint with reinforced rubber seal for large movements

In this domain, waterproof expansion joints in the shape of comb are frequent as well (figure 10).

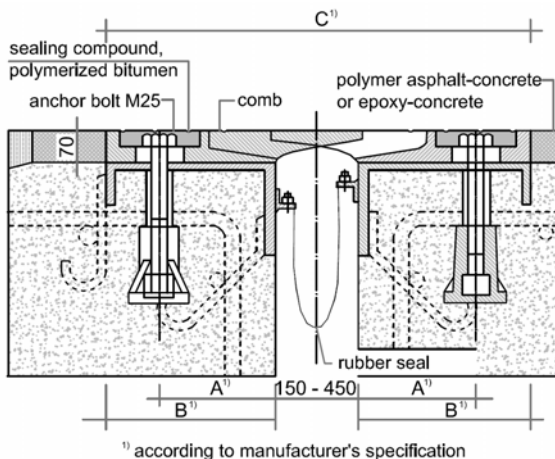

Figure 10: Principle of comb expansion joint with seal for large movements

In case of expansion joints for large movements, accordance with criteria stated in the introductory chapter shall be verified very prudentially at any rate.

5.6. Expansion joints for extremely large movements

All that is stated in the previous chapter (5.5.) applies to expansion joints for extremely large movements as well. However, the approach shall be even more sophisticated.

6. APPOINTMENT OF EXPANSION JOINTS AND ACCOMPANYING TECHNICAL DOCUMENTS

This chapter comprehends basic instructions to appoint the type and moving capacity of an expansion joint as well as the extent of the accompanying technical documents serving for ordering the expansion joints from the selected manufacturer.

The fundamental criteria to determine the expansion joint type are as follows:

- magnitude and direction of movement,
- type of bridge structure (material, static system),
- road category,
- quality,
- method of ensuring drainage, and
- price.

The selection is also influenced by the special conditions to be well considered by the designer, also from the point of view of maintenance and replacement (e.g. jams on heavy traffic roads). In case of roads with extremely heavy traffic, the criterion of a simple and quick replacement prevails over the price.

6.1. Design calculation in general

In the design calculation, magnitude and direction of movements as well as reactions in the expansion joint affecting the abutment and superstructure elements are determined.

The design calculation for the expansion joint is a constituent part of the bridge design calculation.

In the design calculation, first the static system is defined, the centre of movements specified, and the distance between adjacent expansion joints determined. Construction stages and time schedule shall be taken into consideration. Then, directions and magnitude of movement vectors in the expansion joint are specified considering the geometry and static system of the bridge, arrangement of bearings, actions on the bridge, own deformations of structural elements, deformations of foundation ground, etc.

6.2. Calculation of movements in expansion joint

In the calculation of movements serving for determination of the required moving capacity of an expansion joint, provisions stated in chapter 6.1 of the DIN 1072 (1985), and appurtenant explanations (Appendix 1), shall be assumed.

Movements are specified taking into consideration the principal, additional and special loads (§3, §4, and §5 in the DIN 1072) in their most unfavourable combination with the following actions:

- superstructure: temperature change, pre-stressing, shrinkage and creeping of concrete, effects due to superstructure deformations (e.g. rotation above the bearing);
- substructure: movements and/or rotations of structural elements.

To calculate the movements in expansion joints, the following provisions shall be additionally taken into consideration:

- When calculating movements due to a temperature change, fictive limit mean temperatures of the structure in accordance with the table 2 are assumed; for both concrete and steel structures, the coefficient of the temperature elongation of $\alpha T = 1.2 \times 10^{-5}$ is adopted.
- When determining the expansion joint opening, the starting temperature of $+10^\circ\text{C}$ specified by the DIN for the design calculation of the bridge structural elements is not allowed for; namely, the actual measured mean temperature of the bridge structure is relevant.
- Values given in the table 2 can be reduced, when the expansion joint is accurately adjusted to the measured temperature (mean temperature of the structure of the final static system) during its installation; in this way, for bridges stated in the first row of the table 2, both limit temperatures can be reduced by 15°C , whereas for bridges stated in the second row of the same table, they can be diminished by 10°C .
- In case of an expected change of the position of the centre of movements, increased values of the limit temperatures by 15°C and 10°C , respectively, shall be considered due to the construction progress.
- In the calculation of concrete shrinkage and creep effects, unfavourable actions shall be increased by a factor 1.3. Favourable actions are not taken into consideration.

The final value of concrete shrinkage and the final value of concrete creep coefficient as well as the time history shall be taken from the relevant codes.

Table 2: Fictive limit temperatures

Bridge type	Fictive maximum temperature	Fictive minimum temperature
Steel and composite bridges	+ 75°C	- 50°C
Concrete bridges and bridges with steel profiles embedded in concrete	+ 50°C	- 40°C

On the basis of calculated data on directions and limit values of movements as well as movements for a temperature change of 1K in the expansion joint, the designer shall work out a protocol for placing the order. This protocol is a constituent part of the bridge construction design.

In table 3, an example of such protocol is presented.

The calculation of the expansion joint moving capacity gives us an assurance that the expansion joint will function within the range where its moving capacity is not exceeded.

6.3. Drawings

The bridge construction design shall include the expansion drawing as well. The latter serves the expansion joint manufacturer to prepare workshop drawings.

The expansion joint drawing shall comprise all required height levels determining the expansion joint geometry, with indicated direction changes, height differences, position in plan with respect to the bridge axis, eventual direction changes and curvatures in plan, location of eventual field welds, details in walkway and edge beam areas, including details of covering plates, etc. In addition, the drawing shall include all the details related to the installation, the essential data on material quality, and requirements referring to the corrosion protection as well as all the required remarks. In figure 11, the required dimensions to be entered in the expansion joint drawing are given, whereas in figure 12, an example of an expansion joint workshop drawing is presented schematically.

Table 3: Example of protocol for placing the order for expansion joint

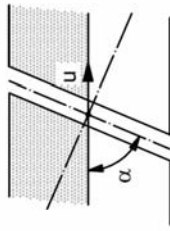

Investor:.....
 Design:.....
 Bridge:.....
 Place of installation:.....

Item	Type	MOVEMENTS IN EXPANSION JOINT			Opening width (mm)	EXPANSION JOINT DIMENSIONS			Angle between expansion joint axis and bridge axis (°)	Covering steel plate (yes/no)	Delivery time (weeks)
		longitudinal »UX« (mm)	transversal »UY« (mm)	vertical »UZ« (mm)		walkway »L1« (mm)	carriageway »L2« (mm)	walkway »L2« (mm)			

Date:..... Signature:.....

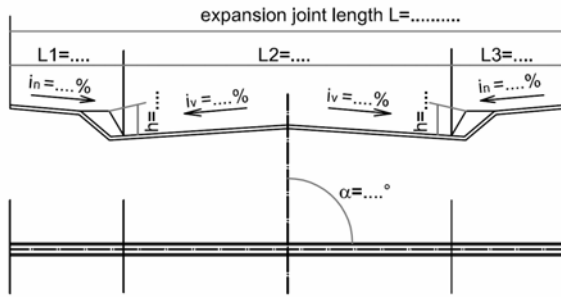

Figure 11: Essential dimensions in the expansion joint drawing

On the basis of the protocol for placing the order as well as of the expansion joint design drawing, the selected manufacturer prepares a workshop drawing, which includes all the data required for the expansion joint adjustment during its installation.

The manufacturer is obliged to submit his workshop drawing to the designer for approval.

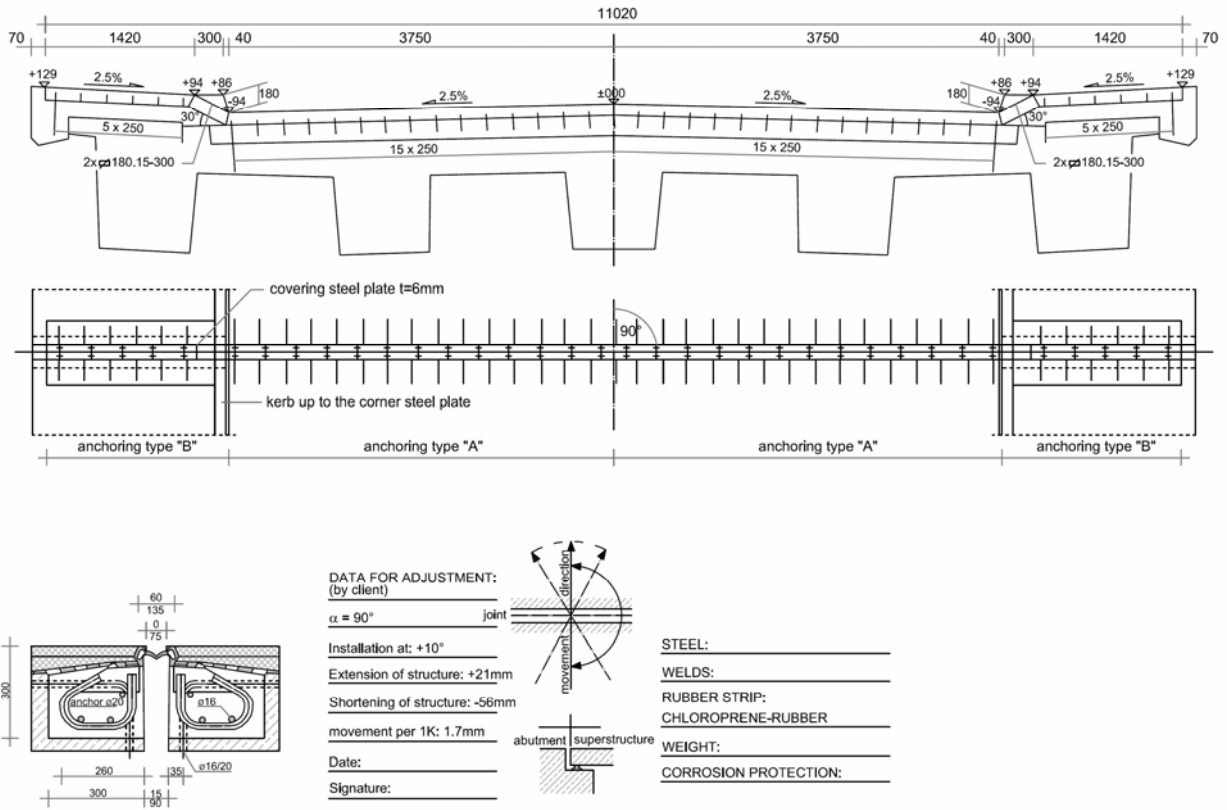

Figure 12: Example of expansion joint drawing

7. Requirements for bridge structure in expansion joint area

This chapter deals with the guidelines for the bridge construction design with respect to the requirements imposed by the expansion joint installation.

7.1. General

In general, when designing bridge elements into which the expansion joints will be installed, a sufficient cross section shall be ensured enabling a reliable installation and a correct transfer of forces from the expansion joint anchorage into the bridge structure.

For all the bearing structural elements that take traffic actions from the expansion joint,

traffic load according to the DIN 1072 with a dynamic factor $\varphi = 1.4$ shall be considered.

In the bridge conception, a simple and effective drainage of surface and seepage water from the expansion joint area shall be taken into consideration. This also applies to cases where water-tightness of expansion joints fails to function properly.

Moreover, sufficient ventilation of the opening below the expansion joint and of the structural elements in the expansion joint area shall be ensured. For this purpose, in case of more complex expansion joints, a joint of minimum width of 15 cm shall be foreseen below the expansion joint (figure 13).

When designing reinforcement, it shall be born in mind that after installation of the expansion joint, a protective concrete cover of minimum 4.5 cm shall be feasible in all places.

Inspection and subsequent replacement of expansion joints shall be ensured as well. Attention shall be paid to the traffic jams, which must be kept within acceptable limits. In the technical report of the bridge construction design, precise installation instructions shall be included, whereas the bridge maintenance design shall comprehend instructions for inspection, maintenance, and replacement of the expansion joint.

7.2. Bridge superstructure

- In the bridge superstructure, an adequate and sufficiently large groove for expansion joint installation with a correctly designed anchoring reinforcement (for anchored expansion joints), and sufficient dimensions and deviations for bolted fastenings, respectively, shall be foreseen.
- If possible, the remaining thickness of the structure around the groove shall amount to at least 20 cm, unless the conditions of taking the loads prior to hardening of the groove concrete require greater dimensions.
- In the walkway area, a simpler execution of anchoring shall be considered.
- In superstructures reinforced with pre-stressed tendons, the vicinity of tendon anchorages shall be taken into consideration, in particular the possibility of damaging them.
- The minimum spacing between an expansion joint anchor and a tendon anchorage shall amount to 20 cm.
- All structural elements in the expansion joint area (e.g. cross beams) that might come into contact with the carriageway water in case of damaged expansion joint shall be equipped with suitable eaves.
- When an expansion joint type is installed that requires intercepting of water by means of a trapping gutter placed in the expansion joint opening, all manufacturer's instructions for a proper installation of the expansion joint and for the gutter dewatering shall be fully respected. All essential requirements stated above are shown in figure 13.

7.3. Bridge substructure

- In case of bridges where the distance between adjacent expansion joints is greater than 100 m, a control walkway is foreseen on the abutment enabling inspection of the expansion joint from below.
- The rear wall of the abutment into which the expansion joint is installed shall be at least 40 cm thick or more, if this is required by the manufacturer's specification.
- The abutment upper surface below the expansion joint shall be designed with adequate falls and drainage gutters collecting the water in case that the expansion joint fails to be waterproof.

7.4. Waterproofing, asphalt, kerbs and walkways with edge beams

- When designing an expansion joint, the profile on the carriageway and on the pedestrian walkway shall be considered. The position of the bridge carriageway dewatering line is particularly important. In this place, the expansion joint is drained as well.
- When detailing an expansion joint in the pedestrian walkway and cycle track area, a perfect connection of the waterproofing to the expansion joint shall be ensured below the walkways and in the edge beam area as well.

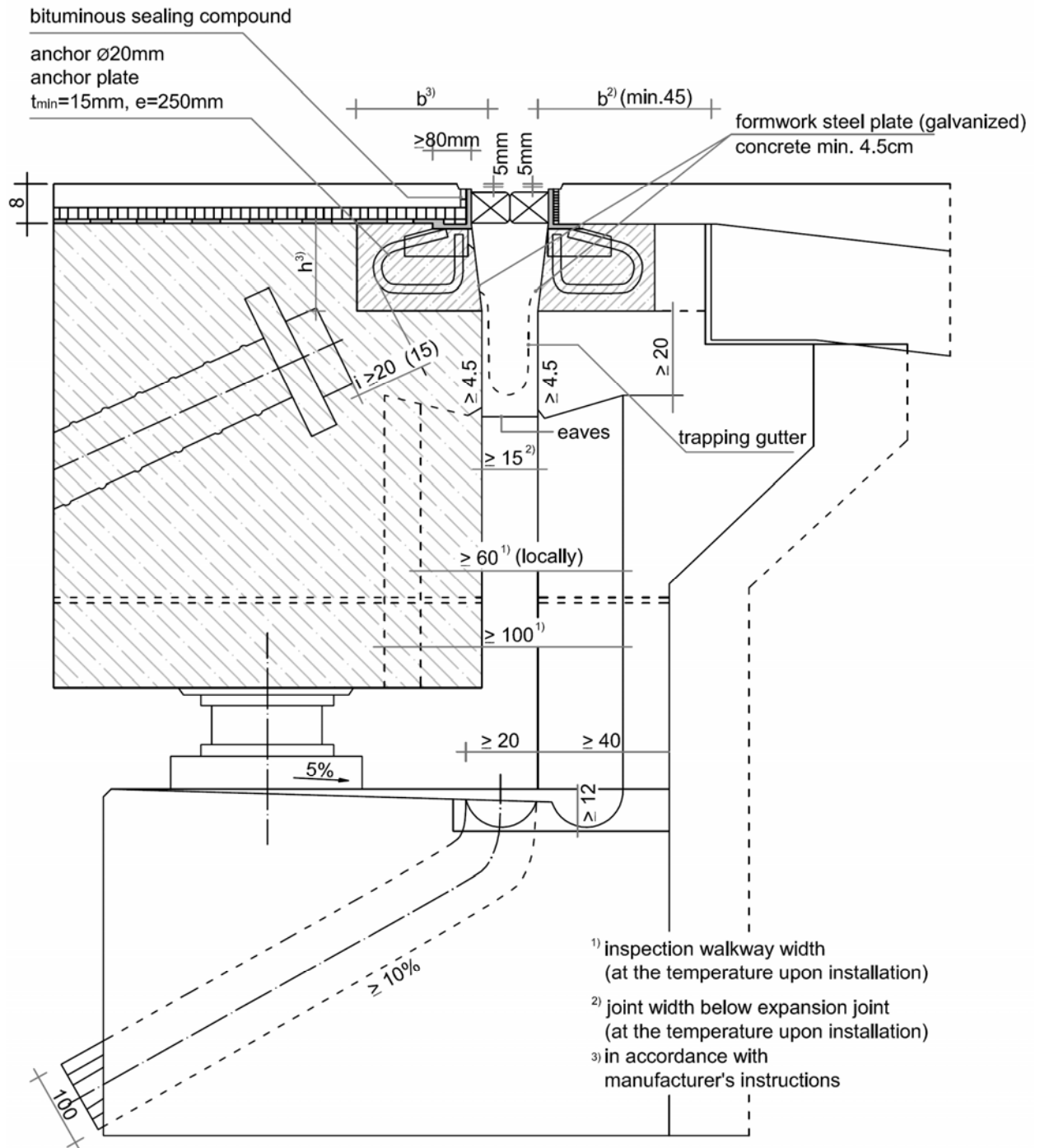

Figure 13: Design of structural elements in the expansion joint area

On principle, an expansion joint is led in the pedestrian walkways on the level of the superstructure where it is anchored as well (figure 14). Such execution does not require sealing of installation ducts because the water runs from those ducts onto the waterproof expansion joint. This is also suitable for expansion joints made of heavy rubber seals since no direction changes are required or these are insignificant.

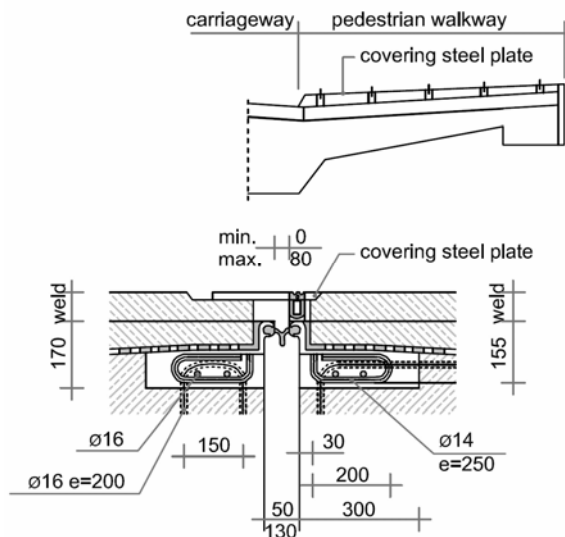

Figure 14: Expansion joint in walkway area (led below, i.e. on the superstructure level)

An expansion joint can be led in the walkway upper surface at anchoring to the superstructure (figure 15). This method offers a reliable raised connection of the waterproofing, whereas installation ducts cannot be led.

Furthermore, attention should be paid to the expansion joint seal, which must be raised on its ends in order to prevent water to flow away.

When the pedestrian walkway surface is intended for public pedestrian traffic and/or cyclists, the expansion joints in the walkway area shall be designed to ensure a safe passing of pedestrians, cyclists, and disabled persons.

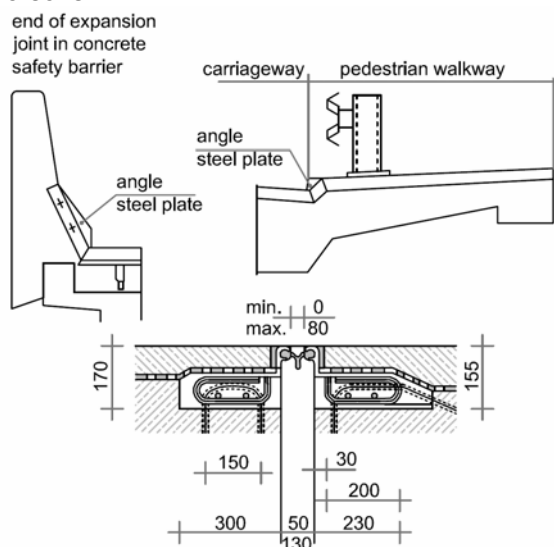

Figure 15: Expansion joint in walkway area (led above, i.e. in the walkway upper surface)

When communal installations in walkways are equipped with expansion joints, the possibility of inflow of condense or surface water via installation ducts shall be considered. This should be particularly born in mind in case of leading the expansion joint "above" (figure 15).

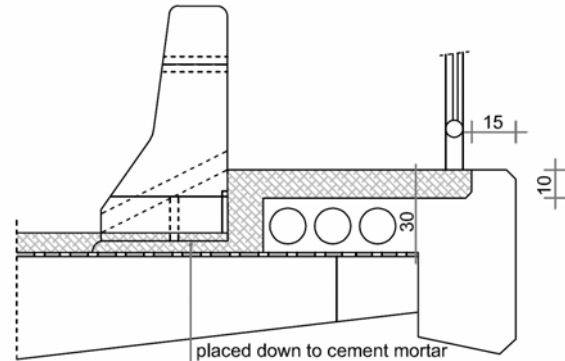

Figure 16: Execution of asphalt expansion joint at concrete safety barrier

7.5. Drainage

- When designing a bridge and subsequently its dewatering, such solutions shall be adopted that ensure a smallest possible inflow of surface water to the expansion joint area. For this purpose, a bridge gully is built-in next to the expansion joint in the carriageway drainage line.
- Alternatively, an outflow from the channel on the connecting fill can be arranged, when the expansion joint is located on the higher side of the bridge.
- On bridges with long parallel wings a gully is installed next to expansion joint. A similar solution is foreseen on bridges where the water flows at wings thus entering the expansion joint area.
- Next to expansion joint, the seepage water is intercepted to a greatest possible extent as well.
- The seepage water shall also be drained away from all depressions that arise from the raised ends of the waterproofing at the expansion joint.

7.6. Checking of procedures prior to placing an order for expansion joint

To avoid inattentions prior to placing an order for installation joint(s), the design solutions shall be checked. The review is carried out on the basis of a checking-list attached by renowned manufacturers to their technical documents.

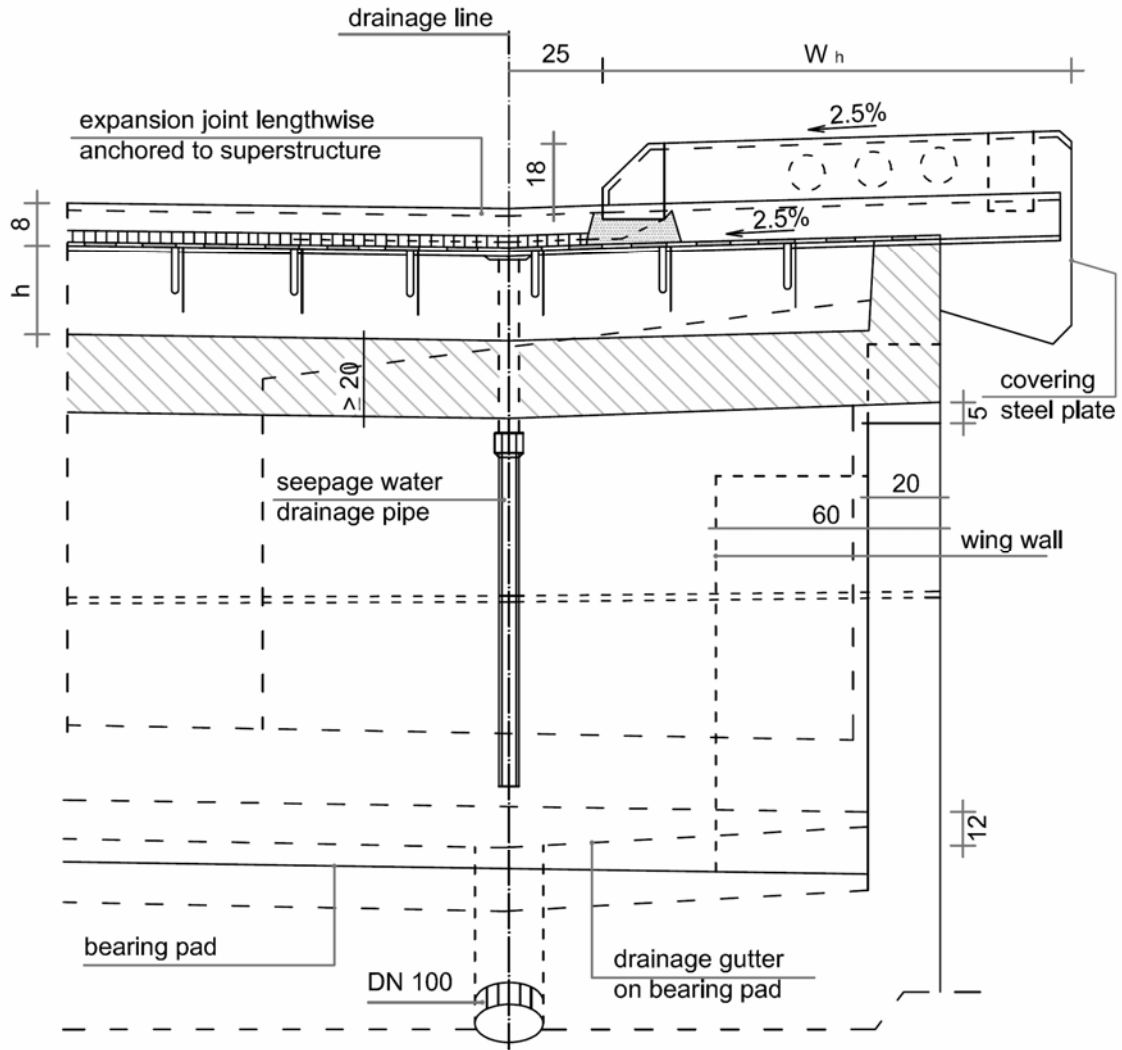

Alternative - leading of expansion joint in walkway above

ducts of cable installations below expansion joint - ducts to be equipped with waterproof expansion joints

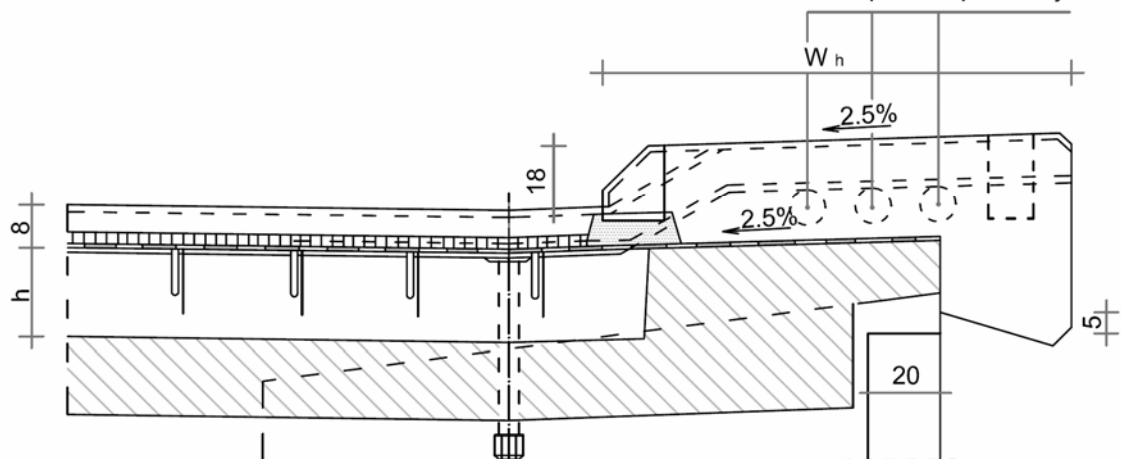

Figure 17: Design of structural elements in expansion joint area – walkways

8. TAKING OVER, INSTALLATION, MAINTENANCE, AND REPLACEMENT OF EXPANSION JOINT

8.1. Taking over of expansion joint from manufacturer

Expansion joint is taken over by the construction site manager. In case that his knowledge is insufficient, an expert shall be engaged.

During taking over, dimensions, materials and corrosion protection are examined and compared to those specified in the design. The results shall be entered in a suitable record (table 4). Moreover, it shall be checked whether the expansion joint possesses all required technical documents, i.e. attestation certificates, a guaranty document, and manufacturer's instructions. The manufacturer's instructions shall comprise the following provisions in connection with the expansion joint:

- storage,
- transportation,
- installation,
- maintenance, and
- replacement.

The acceptance procedure shall be carried out by means of an appropriate checking-list.

The suitability of the expansion joint at taking over shall be certified by an entry in the record comprising all the stages up to the technical acceptance of the expansion joint (table 4).

8.2. Installation of expansion joint

Expansion joint is installed in accordance with design and manufacturer's instructions, after the investor's engineer has verified the suitability of both expansion joint and structural elements into which the expansion joint will be built-in.

An appropriate checking-list for this activity is required as well.

Installation of complicated expansion joints shall be inspected by an adequate committee constituted of engineer's representative, construction site manager, designer, manufacturer's representative, and, if required, representative of an authorized company for testing materials and structures. The suitability of conditions for installation is certified by entries in the record mentioned above (table 4).

When the contractor is incapable to install an expansion joint by himself, he is obliged to engage an appropriate subcontractor or an instructor.

The most essential general instructions are given below. In addition, specific design requirements and installation instructions/requirements by the expansion joint manufacturer shall be taken into consideration.

8.2.1. Installation of bituminous expansion joints and elastomer fillers

- With regard to other bridge construction works, expansion joint shall be installed as late as possible, and in conditions that will in the subsequent operation of the expansion joint ensure minimum possible extensions of its movable parts.
- During the application of asphalt carriageway layers, a groove for building-in of expansion joint shall be carried out. The groove dimensions shall be harmonized with the data supplied by the manufacturer. Lateral sides of the groove shall be cut by means of a joint cutting tool up to the waterproofing layer.
- The groove shall be cleaned and eventual damages of concrete surface repaired. Into the joint, a seal made of foamy rubber shall be built-in. Then, an adhesive layer of elastic polymerized bitumen is applied, and an aluminium strip to bridge the movable joint is installed. This strip is fixed by inserting nails. Afterwards, the filler is built-in and the wearing course of polymerized bitumen applied.
- For all procedures described above the manufacturer is obliged to submit an attestation certificate on installation conditions and procedure, as well as on the suitability of the materials used.

8.2.2. Installation of rubber expansion joint

- Immediately after being delivered to the construction site, the expansion joint shall be properly stored (unless it is installed immediately after delivery) to prevent damages and dirtiness.
- Expansion joint shall be installed as late as possible. This is particularly essential in case of bridges with a higher rate of development of long-term time deformations (concrete shrinkage and creeping, consolidation of foundation soil).

Table 4: Record of expansion joint (example)

Bridge (road section, designation, position):			
Client (investor):			
Receiver:			
Expansion joint manufacturer's name, order number:			
Number of expansion joint certificate, issued by:			
Validity of certificate:			
Contractor, site manager:			
Designing bureau, responsible designer:			
Number of bridge execution and expansion joint installation design:			
Investor's engineer, responsible supervisor:			
No.	Stage	Description	Entry
1	Expansion joint basic data	Installation location (No. of support, axis)	
2		Expansion joint type	
3		Moving capacity perpendicular to expansion joint axis	
4		Movement at 1°C	
5		No. of technical documents for expansion joint, validity	
6	Delivery of expansion joint to construction site	Date of taking over at manufacturer's workshop	
7		Date of delivery to construction site	
8		Marking on expansion joint	
9		Expansion joint delivered in perfect condition (yes/no)	
10		Integrity of all steel elements and blocking	
11		Condition of corrosion protection of steel elements	
12		Integrity of rubber seal	
13		Expansion joint properly deposited, supported, protected	
14	Before installation	Adequacy of groove and niche dimensions	
15		Cleanliness and preparation of contact surfaces	
16		Adequacy of anchor reinforcement	
17		Adequacy of holes for anchor bolts	
18		No. of technological design for installation	
19	No. of geodesic report on geometry survey		
20	During installation	Date / hour	
21		Superstructure temperature in °C	
22		Width of joint opening	
23		Adequacy of expansion joint fastening (geometry)	
24		Adequacy of expansion joint fastening (firmness)	
25		Expansion joint blocking removed	
26		Corrosion protection, seal(s), cleanliness before sealing	
27		Designation and number of material samples	
28	Service	Date / hour	
29		Superstructure temperature in °C	
30		Width of joint opening	
31		Corrosion protection, seal(s), covering steel plates	

Contractor: _____ Expansion joint manufacturer: _____ Supervisor: _____

Place: _____ Date: _____

Prior to installation, the groove geometry (dimensions and height levels), as well as adequacy of connecting reinforcement in the groove shall be checked. The groove and reinforcement shall be cleaned of all impurities and residuals from concreting.

- In case of steel bridge structures, all edges shall be prepared to carry out filed welds.
- Afterwards, the percentage of already accomplished long-term structural deformations shall be established and the mean temperature of the structure measured. On the basis of those findings the expansion joint opening is set.

- All dimensions shall be thoroughly controlled during construction works (a permanent geodesic control is required).
- The set expansion joint is then placed into the groove and the anchors welded onto the connecting reinforcement. First, all anchors on one side, and then on the other side of expansion joint are welded. In this way, the expansion joint is already connected with the bridge structure; therefore, all elements for fixing the expansion joint during transport and installation shall be immediately loosened.
- The procedure is analogical for expansion joints with bolted anchoring.

- In case of steel bridge structure, first the anchoring profile is welded onto the superstructure; then, anchors at abutment are welded and the blocking removed. The same procedure applies to expansion joint located between two superstructure units.
- After fixing is completed, the suitability of installation is re-checked, in particular the height position, so that the expansion joint will be entirely levelled with the carriageway upper surface after the carriageway asphalt layers are carried out. The prescribed deepening of 5 mm shall be taken into account.
- Finally, after an adequate preparation, concrete is cast into the groove in accordance with the approved procedure.

8.2.3. Execution of waterproofing at expansion joint

Prior to application of waterproofing, cement skin shall be removed from the concrete surface by means of sand blasting, high-pressure water jet, brushing, etc. The waterproofing layer is carefully glued onto the expansion joint profile. The remaining part of the expansion joint is sealed with bituminous compound. The same applies to the previously left joint at expansion joint, which has been formed in the waterproofing protective layer. Alternatively, the protective layer is connected to the expansion joint with bituminous sealing strip. The procedure is defined by the technical conditions for the waterproofing end at vertical boundary surfaces. Special attention shall be paid to all the joints between those boundary surfaces and the expansion joint boundary surface.

8.2.4. Application of wearing course at expansion joint

The wearing course at expansion joint shall be applied with special care. Stiff elements of the expansion joint prevent thickening of bituminous concrete next to expansion joint during rolling, thus leading to crumbling of the wearing course at expansion joint.

Sufficient thickening is achieved in such a way that, prior to rolling, stiff expansion joint elements are covered with small wooden board – template of an appropriate thickness. After the roller has passed the joint several times, the wooden board is removed. The excessive thickness of the wearing course is then compacted up to the prescribed rate by subsequent rolling (the roller must not strand onto the expansion joint). The thickness of the board shall be such that the expansion joint remains deepened by 5 mm below the

carriageway surface after completed rolling. Such deepening enables further compaction of the wearing layer at expansion joint under wheel load. Moreover, in this way the expansion joint is protected from the plough impacts.

8.2.5. Inspection and maintenance of expansion joints

Inspection and maintenance procedure is prescribed by the expansion joint manufacturer. Upon technical acceptance, the contractor hands over the instructions being a constituent part of technical documents to the bridge administration. The latter inserts the prescribed procedure into the technical instructions that serve responsible staff to perform correct inspection and maintenance.

When maintenance works are expected to affect traffic, adequate specialists for traffic regulation shall be engaged.

The maintenance staff shall inspect expansion joints at least once a year. At the same time, bridge structural elements into which the expansion joint is built-in shall be checked as well.

8.2.6. Replacement of expansion joints

Expansion joints shall be replaced in accordance with the procedure that is identical to the installation procedure for a new expansion joint, i.e. on the basis of the execution design documents.

However, the specificity of the replacement procedure shall be taken into consideration. Special attention shall be paid to removal of existing expansion joints because such procedures are destructive and may affect the bridge structure.

Furthermore, it shall be taken into account that expansion joints are often replaced under traffic thus step-by-step installation is required. In such cases, expansion joints shall be equipped with a field joint.

8.2.7. Attestation of expansion joints

Until appropriate European standards are introduced, the suitability of expansion joints is verified and certified on the basis of regulations stated in chapter 2.